

Dear Sirs

We refer to our service letter SL2006-469 concerning accumulators. The information in this letter and in the instructions attached replaces the information given in our service letter SL06-469/JOF.

To prevent undesirable pressure peaks in the hydraulic oil system, we emphasise the importance of checking the nitrogen pressure regularly, which according to the instruction manual means every 2,000 hours or every 6 months, whichever occurs first. Please ensure that the checking procedure is carried out only when the engine is in the Finished with Engine-mode and the hydraulic system is without pressure. The nitrogen pressure must be kept within the limits specified below:

Nominal hydraulic pressure	200 bar	300 bar
Nitrogen charge pressure at 20°C*	95 bar	136 bar
Minimum nitrogen pressure at 20°C*	65 bar	106 bar

**) at other temperatures the correct charge pressure can be found in Datasheet DL10623-0017*

Accumulators leaking more than 5 bar over a period must be overhauled. All details on checking and overhauling of accumulators are described in the attached instructions. However, the following safety related checks should be given special attention:

- Correct tightening of the screws fastening the accumulator
- Regular check of the nitrogen pressure
- Never open the inlet valve to the hydraulic cylinder unit if the hydraulic system is pressurized.

For any further questions regarding this service letter, write to: lep@mandieselturbo.com

Yours faithfully

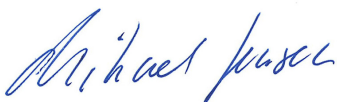

Mikael C Jensen
Vice president, Engineering



Per Pallisgaard
Manager, Engineering

Action code: WHEN CONVENIENT

Accumulators - All Makes and Types

Updated information

SL2017-653/PRP
October 2017

Concerns

Owners and operators of MAN B&W two-stroke marine diesel engines.
Type: ME/ME-C and ME-B

Summary

MAN Diesel & Turbo has revised and updated the relevant chapters in the instruction manuals concerning accumulator maintenance and safety.

Attachments:
Work Card 4565-0551-0024
Datasheet 4565-0550-0002

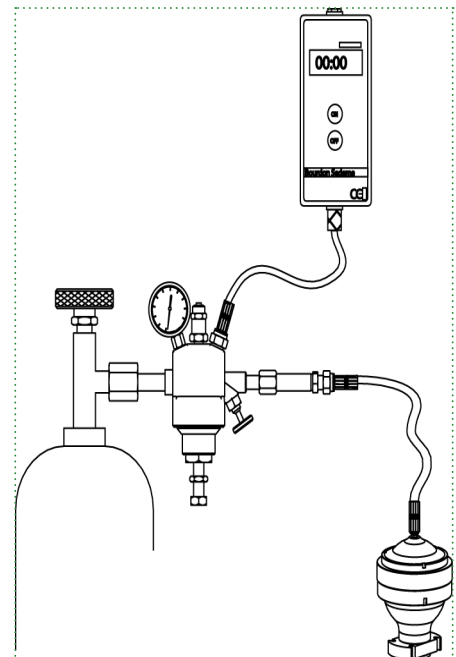

Head office (& postal address)
MAN Diesel & Turbo
Tegholmmsgade 41
2450 Copenhagen SV
Denmark
Phone: +45 33 85 11 00
Fax: +45 33 85 10 30
info-cph@mandieselturbo.com
www.mandieselturbo.com

PrimeServ
Tegholmmsgade 41
2450 Copenhagen SV
Denmark
Phone: +45 33 85 11 00
Fax: +45 33 85 10 49
PrimeServ-cph@mandieselturbo.com

Production
Tegholmmsgade 35
2450 Copenhagen SV
Denmark
Phone: +45 33 85 11 00
Fax: +45 33 85 10 17
manufacturing-dk@mandieselturbo.com

Forwarding & Receiving
Tegholmmsgade 35
2450 Copenhagen SV
Denmark
Phone: +45 33 85 11 00
Fax: +45 33 85 10 16
shipping-cph@mandieselturbo.com

MAN Diesel & Turbo
Branch of MAN Diesel & Turbo SE,
Germany
CVR No.: 31611792
Head office: Tegholmmsgade 41
2450 Copenhagen SV, Denmark
German Reg.No.: HRB 22056
Amtsgericht Augsburg

1. Initial preparations Check of the hydraulic accumulator can only be done with stopped engine and with stopped start-up and booster pumps.

Connect a pressure gauge at minimess point **455**. Check the pressure.

Close the high pressure inlet valve **420** and open the high pressure outlet valve **421** to drain all oil out of the accumulator.

Check that the system is pressure free.

Check the nitrogen pressure.

For correct pressure, *see data T45-45*.

For use of pressure setting tool, see checking procedure, step 3.

2. Check of accumulators on hydraulic power supply unit

Check of accumulators on the accumulator block can only be performed on a stopped engine and with stopped start-up and booster pumps.

Connect a pressure gauge at minimess point **340**. Check the pressure.

Open valve **315** to de-pressurise the hydraulic system and drain all oil out of the accumulators.

Check that the system is pressure free.

Check the nitrogen pressure.

For correct pressure, *see data T45-45*.

For use of pressure setting tool, see checking procedure, step 3.

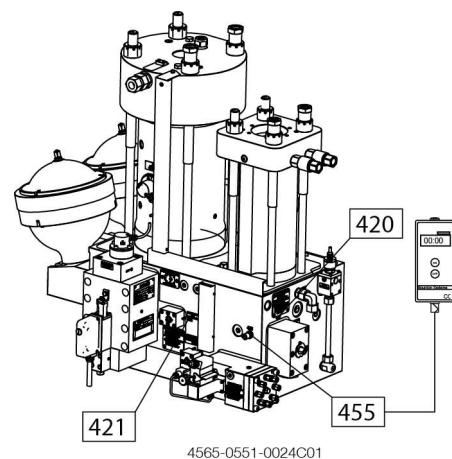

3. Check of accumulators on hydraulic power supply unit

Check of accumulators at the hydraulic oil pumps can only be performed on a stopped engine and with stopped start-up and booster pumps.

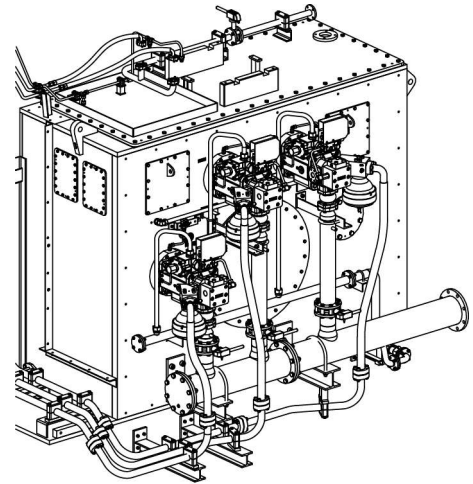

4565-0551-0024C02

4. Procedure for check

Connect a pressure gauge at minimess point **340**. Check the pressure.

Open valve **315** to de-pressurise the hydraulic system and drain all oil out of the accumulators.

Check that the system is pressure free.

Check the nitrogen pressure.

For correct pressure, *see data T45-45*.

For use of pressure setting tool, see checking procedure, step 3.

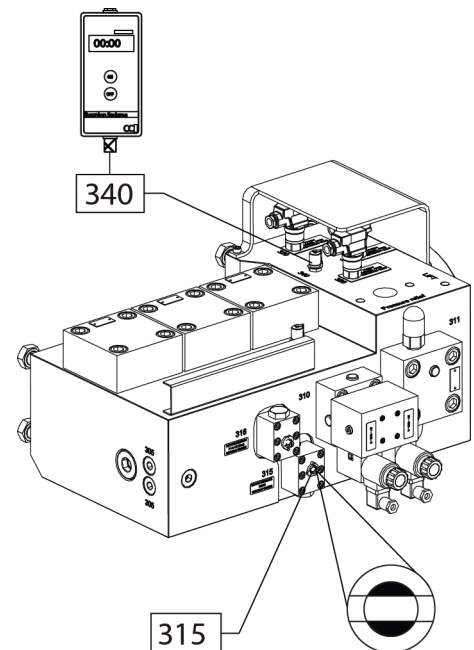

4565-0551-0024C03

5. Refilling the accumulator

Assemble the reducing valve as shown in the figure, and mount the reducing valve on the nitrogen cylinder. If necessary, use a threaded adaptor.

Before mounting the filling hose on the accumulator, check that the accumulator top is clean.

Check that valves **A** and **D** are closed.

Mount the filling hose on the relevant accumulator with the union nut **E**.

It is now possible to read the actual nitrogen pressure in the accumulator on the digital gauge **C** on the filling valve.

If the accumulator needs to be refilled with nitrogen, open valve **A** and adjust the outlet pressure on spindle **B** to 1-2 bar above the pressure stated in the Pressure Adjustment Table. *See data T45-45.*

Keep valve **A** open until the accumulator is filled.

Close valve **A**.

Wait five minutes for the temperature to stabilise.

Check the pressure in the accumulator on gauge **C** according to the Pressure Adjustment Table. *See data T45-45.*

Adjust the pressure in the accumulator at bleed screw **D**.

Unscrew the union nut **E** to remove the filling valve from the accumulator.

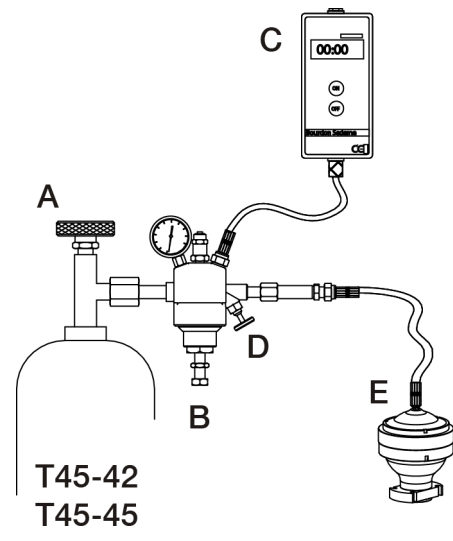

4565-0551-0002C03

Dismantling of accumulators from hydraulic cylinder unit

1. De-pressurise the system Connect a pressure gauge at minimess point **455**. Check the pressure.

NOTICE

Great care must be taken to ensure that the area around the workplace is clean before and during any dismantling of the hydraulic system.

NOTICE

All operation of valves **420** and **421** must only be performed on a stopped engine with stopped start-up and booster pumps.

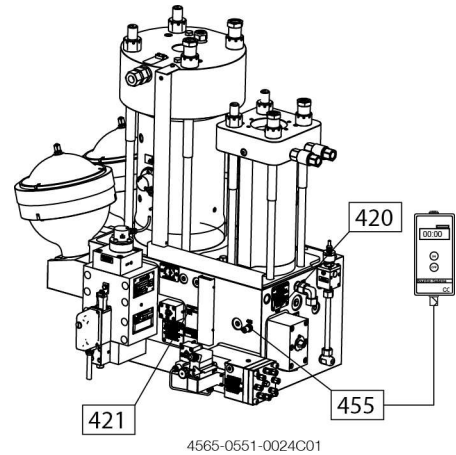

Close the high pressure inlet valve **420** and open the high pressure outlet valve **421** to drain all oil out of the accumulator.

Check that the system is pressure free.

2. Lock the valve Turn the square to closed, lift off the locking disc.

Turn the locking disc 180° and place it on the square again to lock the valve.

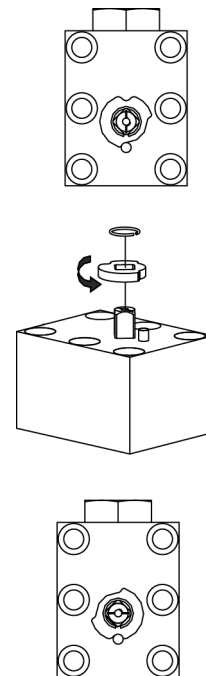

3. Remove the piping Before mounting the lifting tool, remove the piping between the two accumulators (if present).

NOTICE

Depending on engine layout the piping may be different from what is shown in the sketch or omitted completely.

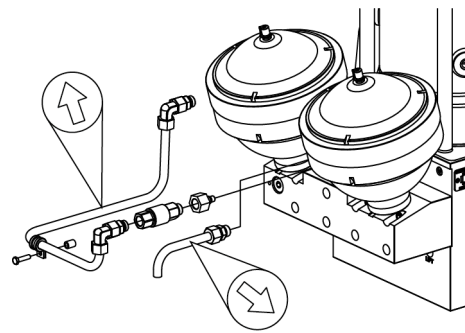

4565-0551-0023D03

4. Mount the lifting attachment Mount the special lifting attachment on the accumulator assembly between the two accumulators.

Use the bolts mounted at the base of the lifting attachment to secure the lifting attachment to the accumulator assembly.

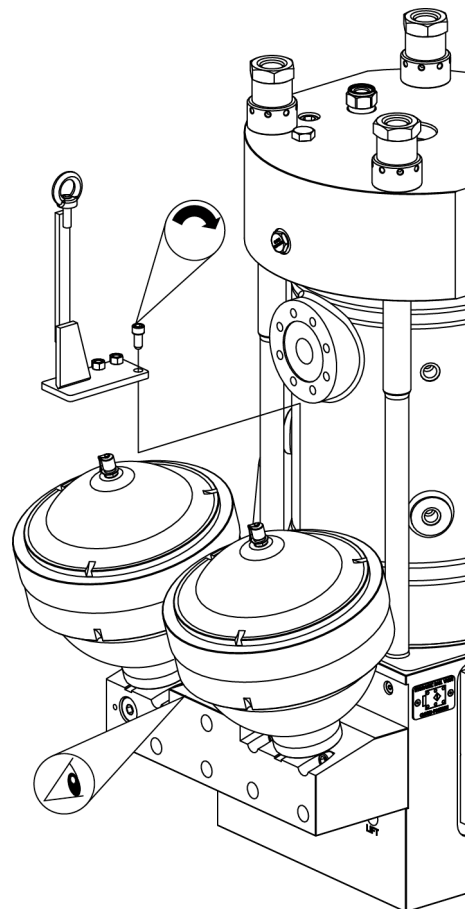

4565-0551-0023D04

5. Remove the accumulator assembly

Hook a tackle and/or the engine room crane on to the lifting attachment. Loosen the bolts which attach the accumulator assembly to the HCU block. Lift away the accumulator assembly.



WARNING

Safe working load (SWL)

Always use lifting gear with sufficient SWL.
See data.

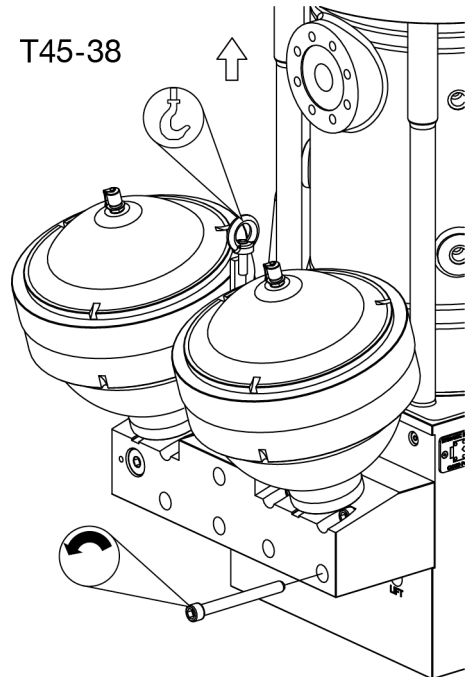

4565-0551-0023D05

6. Remove the lifting attachment

Land the accumulator assembly on a couple of planks, so that the bolts are accessible. Remove the lifting attachment.

If necessary, tip the accumulator assembly on its side so that the bolts attaching the accumulators are accessible.

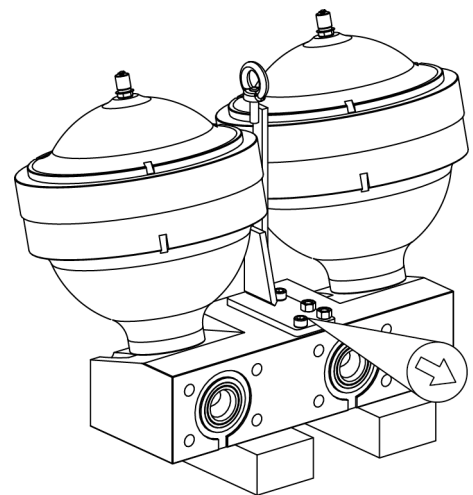

4565-0551-0023D06

- 7. Mount the accumulator lifting tool

Mount the lifting tool around the accumulator to be lifted. Attach a couple of straps. Choose the attachment holes appropriately, so that the accumulator lifts appropriately with the desired tilt. Remove the screws securing the accumulator.

NOTICE

The accumulator lifting tool can only be used for lift of a single accumulator, not the complete accumulator assembly.

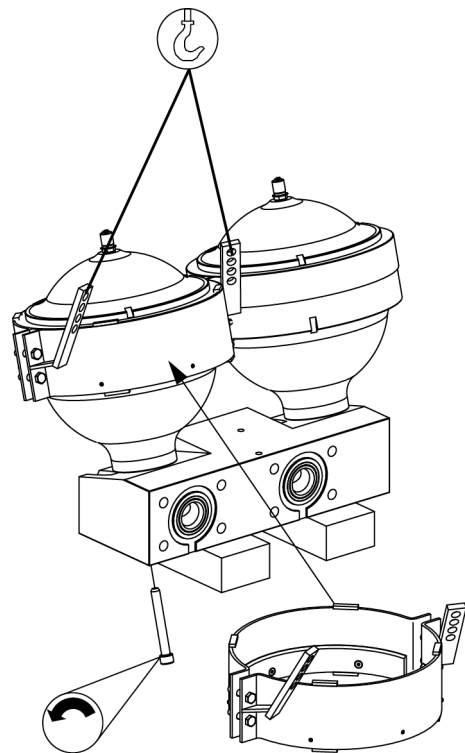

4565-0551-0024D07

- 8. Lift the accumulator

Lift away the accumulator and land it on a wooden plate for overhaul.

Remove and discard the sealing rings from the accumulator block.

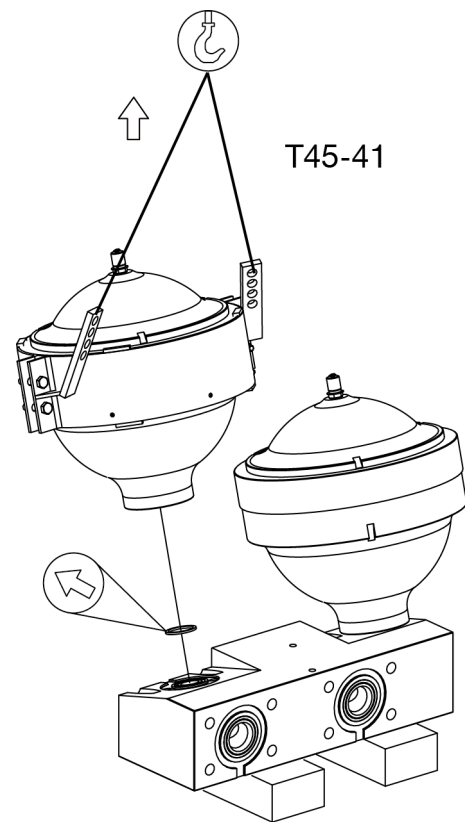

4565-0551-0024D08

CAUTION

NO overhaul may take place until the accumulator has been removed from the accumulator assembly / hydraulic cylinder unit. The bolts securing the accumulator to the accumulator assembly / hydraulic cylinder unit will be damaged, if the accumulator is overhauled while mounted on the accumulator assembly / hydraulic cylinder unit.

NOTICE

The tools for opening the accumulators and the overhaul procedure vary according to accumulator type. This instruction is valid for LEDUC / SGPT type accumulators.

1. Strip accumulator Dismantle the lifting bracket from the accumulator (if present).

NOTICE

The lifting bracket is not standard for all engine types and may be omitted for the specific engine.

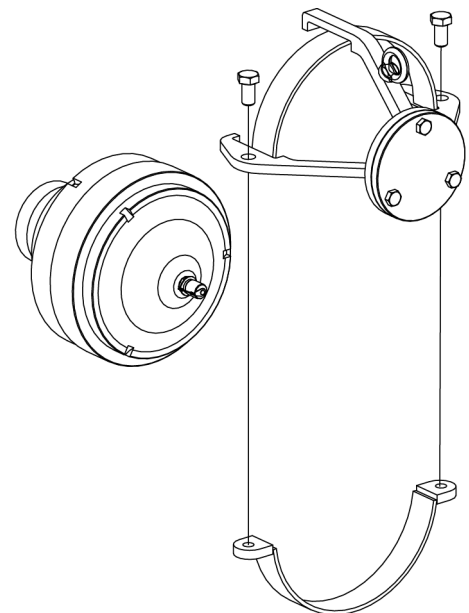

4565-0551-0011001

2. Drain nitrogen Use the pressure adjustment tool to drain the accumulator of nitrogen gas.
See checking procedure.

3. Mount the accumulator in the tool

Mount the accumulator in the pin wrench, which is equipped with three teeth which grip the slots on the lower part of the accumulator.

The ring for the Leduc accumulator fits on the upper perimeter of the accumulator, thus holding the accumulator securely in the pin wrench. This ensures that the accumulator is fixed while the upper part of the accumulator is loosened and removed.

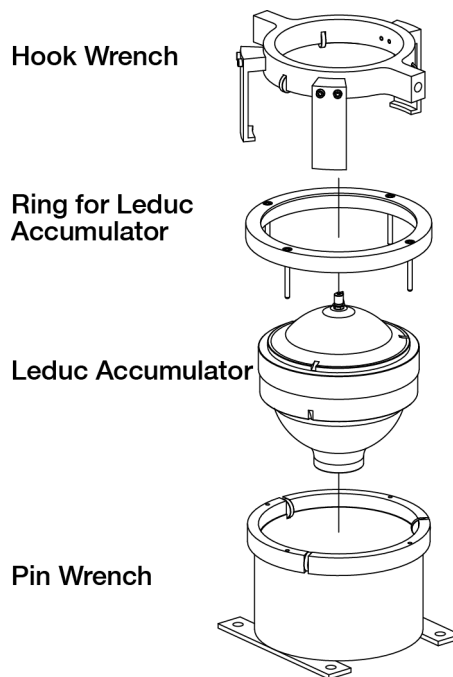

4565-0551-0011002

4. Securing the accumulator tool

Make sure that the pin wrench tool is securely fastened to the engine room deck. This can be done by screwing or welding the flanges of the accumulator tool onto the engine room deck in a convenient place.

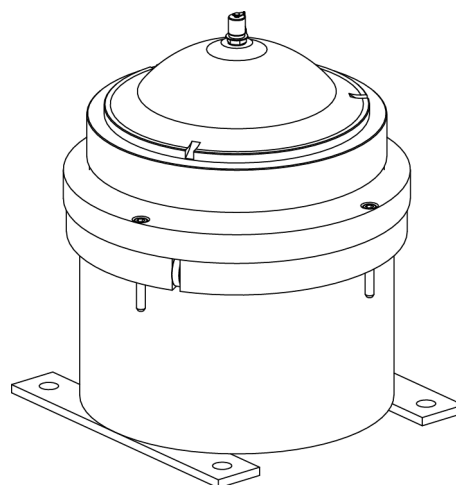

4565-0551-0011003

5. Mounting the hook wrench

After the accumulator is securely mounted within the pin wrench, the hook wrench is mounted on the top of the accumulator.

In order to perform this operation, one of the claws has to be removed. The two claws must reach below the ridge on the accumulator.

Once the two claws are in place and the tool is centred, the third claw is to be re-mounted.

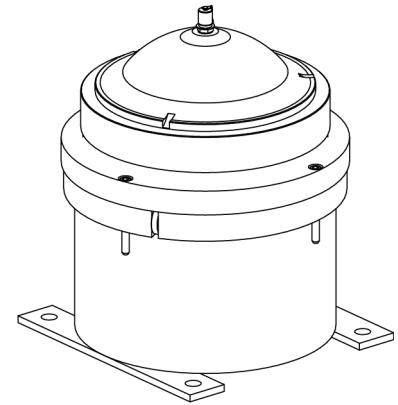
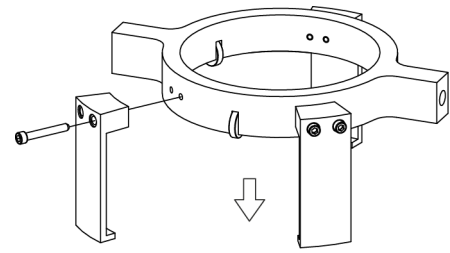

4565-0551-0011004

6. Removing the upper part of the accumulator

Insert a piece of pipe in the holes at the end of the wings of the hook wrench to provide leverage.

If the upper piece binds, it can be loosened by tapping (in counter-clockwise direction) a few times with a hammer on the wings of the hook wrench.

Unscrew (in counter-clockwise direction) and remove the upper part of the accumulator.

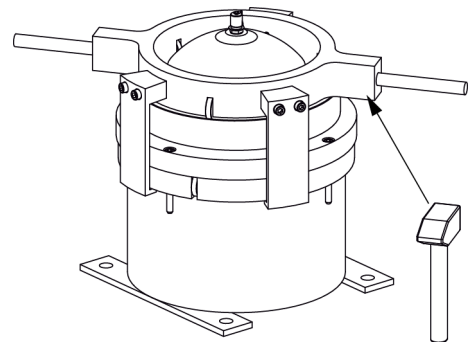

4565-0551-0011005

7. Dismantling Remove the defective diaphragm A.

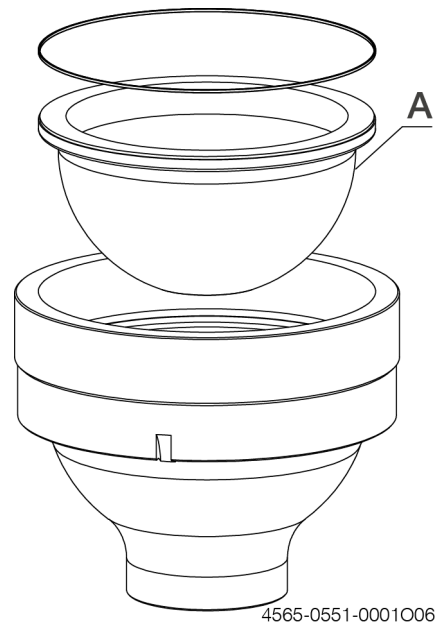

8. Cleaning Clean both accumulator halves thoroughly, especially the threads, and make sure that the parts are dry afterwards.

9. Assembly without diaphragm Assemble the two accumulator halves without mounting the diaphragm. Tighten (in clockwise direction) until the halves are in contact.

Mark the relative position of the accumulator halves.

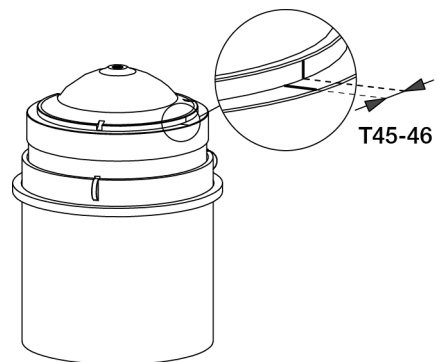

4565-0551-0024012

NOTICE

The mark on the upper accumulator half must be offset relative to the mark on the lower accumulator half, see data T45-46

10. Assembly with diaphragm

Disassemble the accumulator and install the new diaphragm and anti-extrusion ring with the red chamfered edge facing downwards.

NOTICE

Check that the new diaphragm is made of the same material as the old one.

Do not lubricate the diaphragm lip seating.

Lubricate the upper part of the diaphragm lip and the accumulator threads with molybdenum disulphide grease

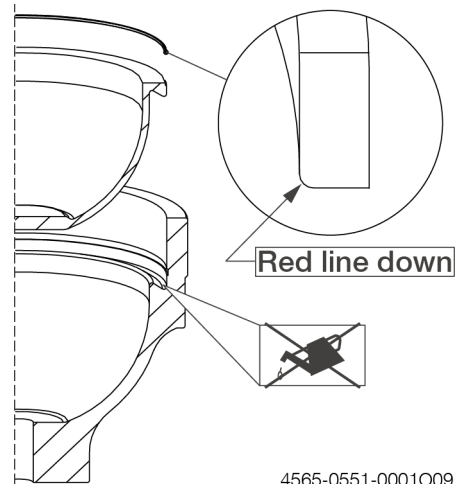

4565-0551-0001009

11. Assemble accumulator

Assemble the accumulator.

Tighten (in clockwise direction) until the marks previously made are aligned.

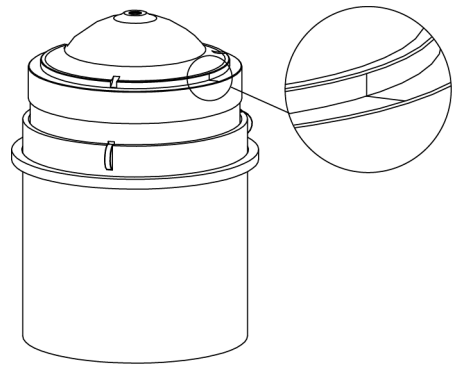

4565-0551-0024014

12. Mount the lifting bracket

Mount the lifting bracket on the accumulator (if present).

NOTICE

The lifting bracket is not standard for all engine types and may be omitted for the specific engine.

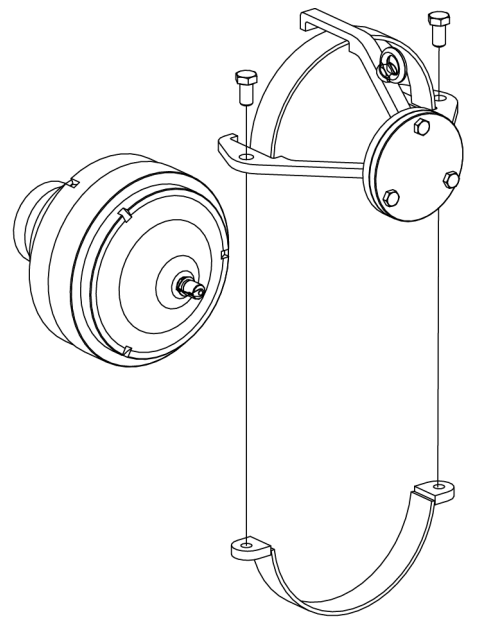

4565-0551-0011001

CAUTION

NO overhaul may take place until the accumulator has been removed from the accumulator assembly / hydraulic cylinder unit. The bolts securing the accumulator to the accumulator assembly / hydraulic cylinder unit will be damaged, if the accumulator is overhauled while mounted on the accumulator assembly / hydraulic cylinder unit.

NOTICE

The tools for opening the accumulators and the overhaul procedure vary according to accumulator type. This instruction is valid for TSP / DAESHIN type accumulators.

1. Strip accumulator Dismantle the lifting bracket from the accumulator (if present).

NOTICE

The lifting bracket is not standard for all engine types and may be omitted for the specific engine.

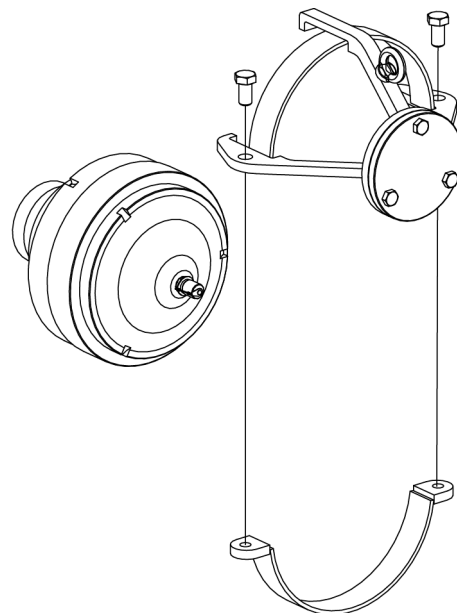

4565-0551-0011001

2. Drain nitrogen Use the pressure adjustment tool to drain the accumulator of nitrogen gas.
See checking procedure.

3. Mount the plate on the accumulator

Mount the plate on the underside of the accumulator.

CAUTION

The screws used for mounting the plate on the accumulator should be discarded after overhaul of the accumulator as the screws will be critically stressed during the disassembly and re-assembly of the accumulator.

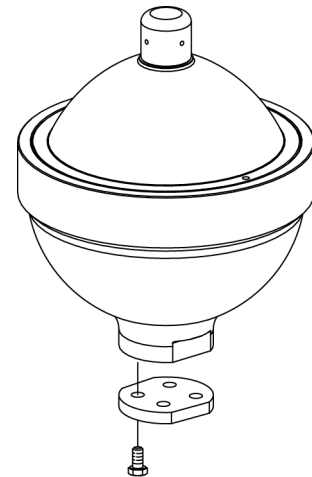

4565-0551-0024002

4. Mount the accumulator in the tool

The accumulator is fixed by means of a specially designed plate which grips the bottom of the accumulator. The plate is fixed to the bottom of the pin wrench. The accumulator is then mounted in the pin wrench and held in place by the ring.

Hook Wrench

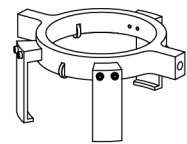

Adaptor ring



Ring for Daeshin Accumulator



Daeshin Accumulator

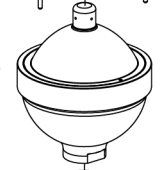

Pin Wrench

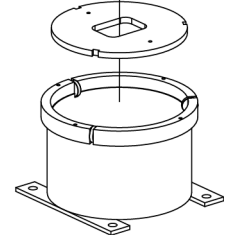

4565-0551-0011006

5. Securing the accumulator tool

Make sure that the pin wrench tool is securely fastened to the engine room deck. This can be done by screwing or welding the flanges of the accumulator tool onto the engine room deck in a convenient place.

6. **Securing the adaptor ring** The adaptor ring is equipped with slots in the upper surface which are gripped by the hook wrench. The lower part of the adaptor ring is equipped with some pins which fit into the upper surface of the accumulator.

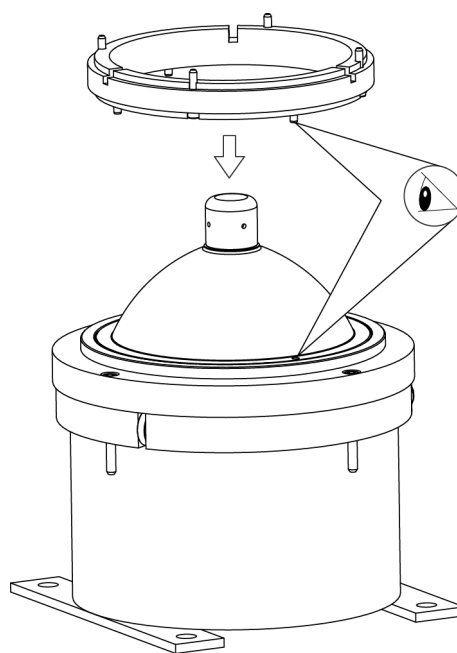

4565-0551-0011007

7. **Removing the upper part of the accumulator** Using the hook wrench unscrew the upper part of the accumulator. Insert a piece of pipe in the holes at the end of the wings of the hook wrench to provide leverage. If the upper piece binds, it can be loosened by tapping (in counter-clockwise direction) a few times with a hammer on the wings of the hook wrench.

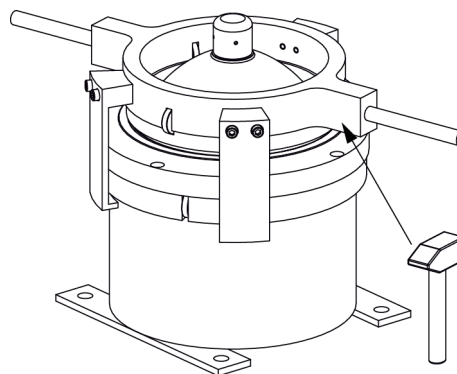

4565-0551-0011008

Unscrew (in counter-clockwise direction) and remove the locking ring of the accumulator.

8. **Remove old diaphragm** Remove the upper part with the diaphragm from the accumulator.

Remove the diaphragm from the upper part and discard it.

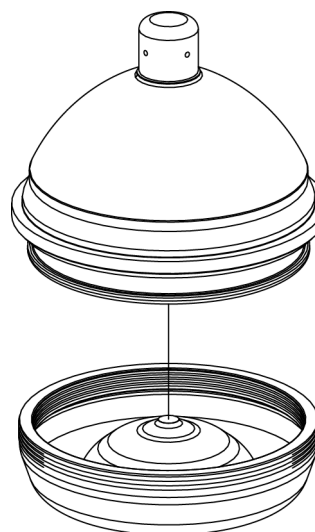

4565-0551-0024006

9. Clean the accumulator
Clean both accumulator halves thoroughly, especially the threads, and make sure that the parts are dry afterwards.
10. Assemble the accumulator
Lubricate the accumulator threads of the lower part and the locking ring with molybdenum disulphide grease.

NOTICE

Check that the new diaphragm is made of the same material as the old one.

Do not lubricate the diaphragm.

Mount the new diaphragm on the upper part of the accumulator and assemble the accumulator in reverse sequence to the dis-assembly.

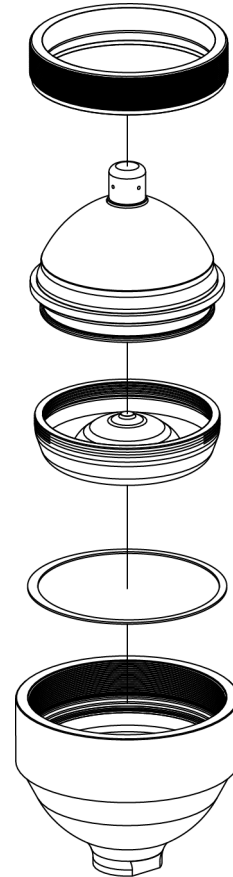

4565-0551-0024008

11. Tighten the accumulator by hand
Using a mandrel tighten the locking ring (in clockwise direction) by hand until it is flush with the lower part of the accumulator.

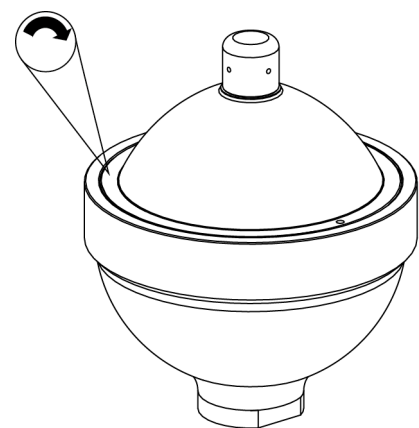

4565-0551-0024009

12. Fully tighten the accumulator

Mount the hook wrench on the upper part of the accumulator in the same way as during dis-assembly. Using a hammer tighten the locking ring of the accumulator (in clockwise direction) until the scratch marks on the locking ring and the lower part of the accumulator are aligned.

Remove the accumulator from the tightening tool and remove the plate from the underside of the accumulator.

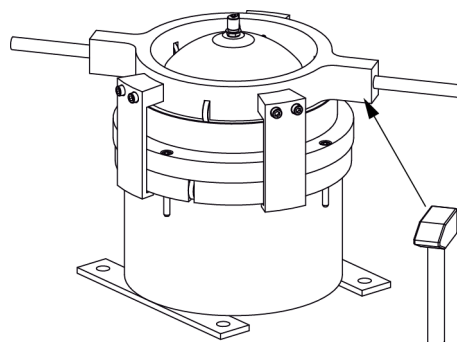

4565-0551-0011005

13. Mount the lifting bracket

Mount the lifting bracket on the accumulator (if present).

NOTICE

The lifting bracket is not standard for all engine types and may be omitted for the specific engine.

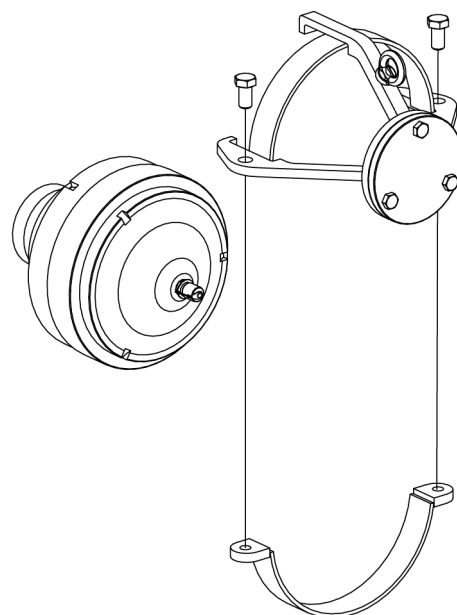

4565-0551-0011001

NOTICE

Great care must be taken to ensure that the area around the workplace is clean before and during assembly of the hydraulic system.

CAUTION

Mounting of the accumulator assembly can only be done on a stopped engine with stopped start-up and booster pumps.

1. Preparations for mounting the accumulator

Check the contact surface on the accumulator assembly. The contact surface must be absolutely clean and no pressing-in marks or other damages may be found.

Mount new sealing rings on the accumulator assembly.

Using the accumulator lifting tool lower the accumulator on to the accumulator assembly. Mount the bolts.

Remove the accumulator lifting tool.

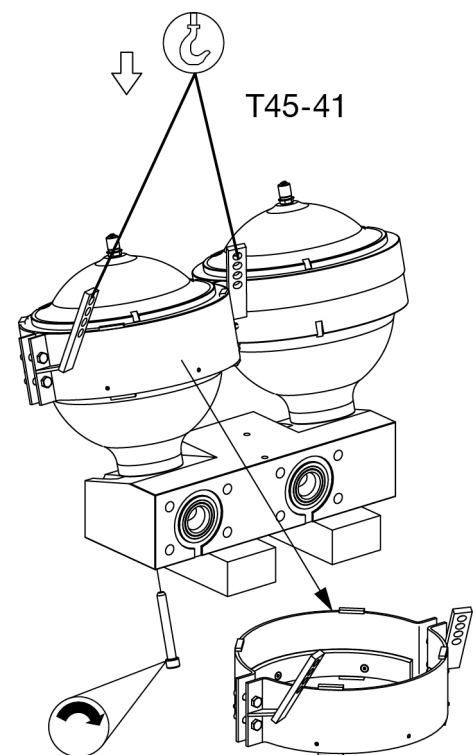

4565-0551-0023M02

2. Tighten the bolts

Tighten the bolts in the sequence shown.

Each individual bolt is to be tightened to the specified torque.
See data. T45-48.

NOTICE

Always tighten the bolts of both accumulators, even if only one accumulator has been removed from the accumulator assembly.

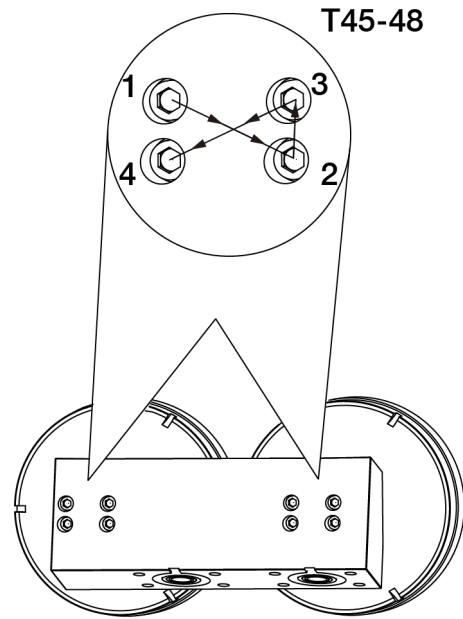

4565-0551-0002M02

3. Mount the lifting tool Return the assembly to an upright position and mount the lifting tool.

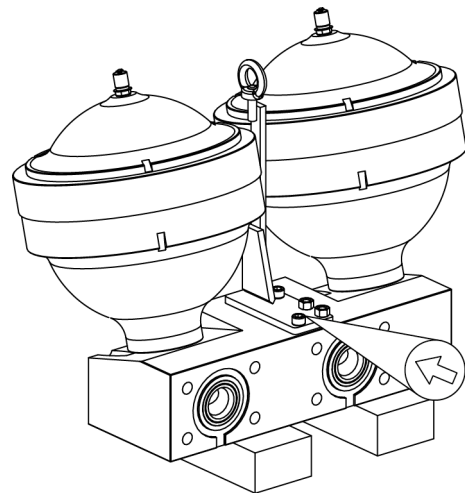

4565-0551-0023M04

4. Inspect the mounting holes

Inspect the mounting holes in the HCU block.

The threads of the holes should be clean with no traces of locktite or other locking compounds. If necessary clean the threads with a thread cutting tap.

Lubricate the threads with a little Molybdenum Disulphide.

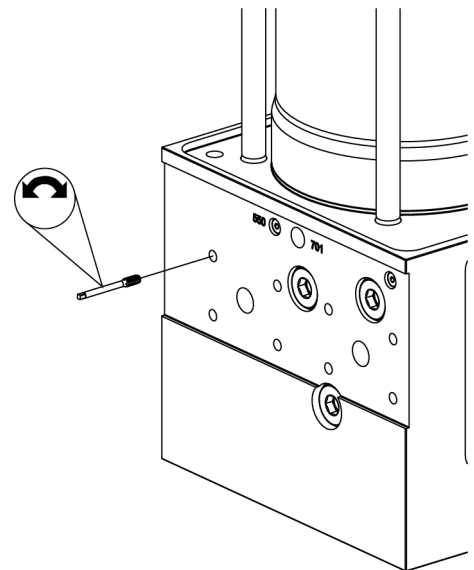

4565-0551-0023M04

5. Mount the accumulator assembly

Mount new O-rings and sealing rings between the flange and the HCU block.

Using a tackle and/or the engine room crane lift the accumulator assembly into position next to the HCU block.

Mount the bolts.

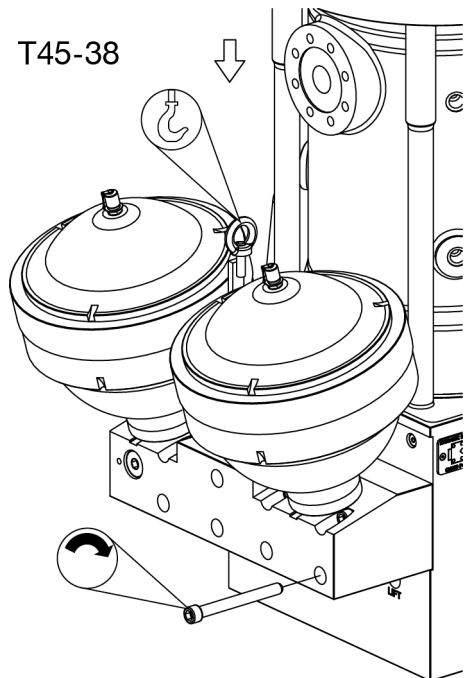

4565-0551-0023M05

NOTICE

Do not use Loctite or other locking compounds.

6. Tighten the bolts

Tighten the 8 bolts using a torque wrench in the following 3 steps (A-B-C) as shown in *data T45-49*.

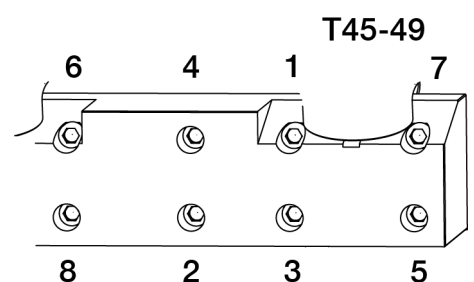

4565-0551-0002M06

- 7. Remove the lifting tool
 Remove the lifting tool and secure the bolts in their place at the tool baseplate.

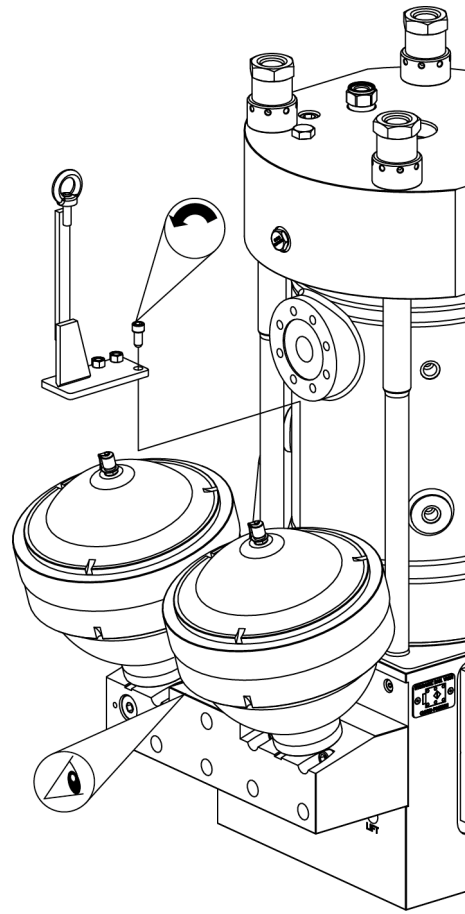

4565-0551-0023M07

Accumulators • Mounting

Work Card
 4565-0551-0024

8. Re-mount piping Re-mount the piping (if present) between the two accumulators.

Tighten the reducer (in front of the non-return valve) to the torque stated in data T45-75.

NOTICE

Do NOT overtighten the reducer.

The piping is not standard on all engines.

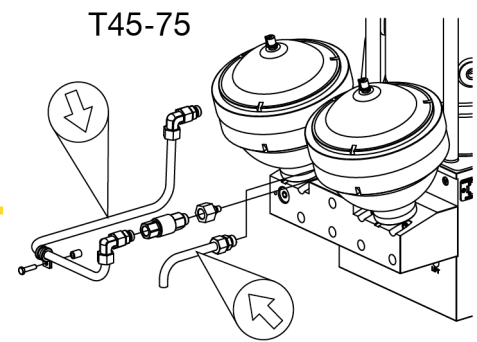

4565-0551-0023M08

9. The small accumulators If the small accumulators have also been overhauled, they are to be re-mounted similarly. These are also to be cross-tightened in the manner also previously described.

10. Re-setting the valves Close the high pressure outlet valve 421 and open the high pressure inlet valve 420.

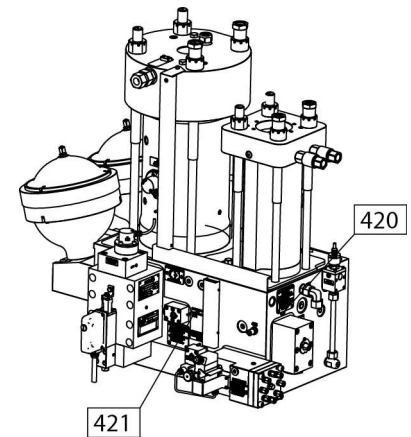

4565-0551-0024M08

11. Nitrogen pressure Check accumulator nitrogen pressure. See data T45-45.

This can only be performed on a stopped engine and with stopped start-up and booster pumps.

12. Mounting of accumulators on hydraulic power supply unit The accumulators on the hydraulic high pressure pumps are mounted in the same way as on the hydraulic cylinder unit. It may, however, not be necessary to use the lifting tool. This depends on the size of the engine. See checking procedure.

Safety Precautions

For detailed sketch see 0545-0100

<input type="radio"/>	Stop the Engine
<input type="radio"/>	Shut off starting air supply - At starting air receiver
<input type="radio"/>	Block the main starting valve
<input type="radio"/>	Shut off starting air distributor/distributing system supply
<input type="radio"/>	Shut off control air supply
<input type="radio"/>	Engage turning gear
<input type="radio"/>	Stop lubricating oil supply
<input type="radio"/>	Shut down hydraulic power supply



Data

Ref.	Description	Value	Unit
T45-38	Flange with two accumulators, weight	200	kg
T45-40	Small accumulator, weight	30	kg
T45-41	Large accumulator, weight	60	kg
T45-43	N2 Charging pressure	136	bar at 20°
-	Accumulator temperature t°C		bar
-	Check pressure within ± 5 bar.		
-	Filling pressure must be as stated above		
T45-45	Pressure Adjustment Table		
-	0° C	124	bar
-	10° C	130	bar
-	20° C	136	bar
-	30° C	142	bar
-	40° C	148	bar
-	50° C	154	bar
-	60° C	160	bar
-	70° C	166	bar
-	80° C	172	bar
-	90° C	178	bar
-	100° C	185	bar
T45-46	assembly off-set 10 - liter accumulator	9	mm
T45-48	Screw, flange to Accumulator	120	Nm
T45-49	Screw, flange to HCU. 3 step tightening	70 + 130 + 130	Nm
T45-75	Reducer, tightening torque	Nm	40

The task-specific tools used in this procedure are shown on the plates at the end of this chapter or in the chapters indicated by the first two digits in the plate number, e.g. **2570-0010** refers to chapter 25, Bearings.

Tools

Plate	Item No.	Description
4570-0540	-	Test equipment for accululators
4570-0550	-	Tools for accumulator
7670-0200	-	Torque spanners
7670-0300	-	Lifting tools, etc
7670-0410	066	Slide caliper